

Captor™ 4300B & 4800B

Battery Rider Sweeper-Scrubbers



Advance
by Nilfisk-Advance

FACT SHEET



Superior cleaning results and increased productivity in a quiet, fume free package.

The Advance Captor™ Battery Rider Sweeper-Scrubber is best in class when it comes to value, productivity and cleaning results. The modular Captor™ platform consists of a high performance sweeping system with dust control and high dump hopper, and a scrub deck that can be sized to match the facility. It can operate as a stand alone sweeper, scrubber or as a highly productive combination sweeper scrubber.

- **THE POWER OF BATTERY:** The battery Captor™ provides the productivity of an engine machine without the noise, maintenance costs and fumes. Standard on the battery Captor™ is a battery roll-out system, allowing it to run continuously.
- **PRODUCTIVITY:** The Captor™ 4800 has been designed with the largest in class 80 gallon tanks and 9.2 cu. ft. hopper. This result is more time cleaning and less time dumping and refilling. And, because the Captor™ can sweep and scrub in a single pass, it does the work of two machines with one operator.
- **PERFORMANCE:** The Captor™ delivers superior cleaning results! The sweep system provides the largest available main broom for its size, for better sweeping and dust control. The dust control system stays active even while the hopper is raised for dumping. The variable scrubbing down pressure up to 400 lbs. allows the Captor™ to remove heavy build-up. The vacuum recovery system leaves floors clean, dry and ready for immediate use. With the Captor's side squeegees, the floor is left dry even on sharp turns.
- **MAINTENANCE:** All common maintenance and inspection points are accessible without tools. In addition, the Captor™ is BUILT TOUGH with rugged components to maximize up-time.
- **SAFE AND EASY TO USE:** Operation is easy and comfortable with the Captor's "Comfort Zone". All cleaning systems are activated with a simple "One-Touch™" keypad. The offset hopper design gives the operator a "Clear-View™" of the critical sweeping area and dumping action, without having to strain their back and neck. This allows the operator's head to remain safely inside the machine and out of danger.
- **MODULAR DESIGN:** Select the scrub deck size that best meets your needs. The Captor™ has a 51" or 62" sweep path with optional 43" or 48" scrub decks.

For Superior productivity and cleaning results, the Advance Captor™ Battery delivers.

STANDARD FEATURES INCLUDE

- Combo Sweeper-Scrubber
- Quiet and emission free operation
- Lower maintenance than an engine unit
- Productivity Sweeping up to 163,700 sq. ft/hr
- Productivity Scrubbing over 84,500 sq. ft/hr
- Designed with Total Clean™ Technology
- Operator "Comfort Zone"
- Clear-View™ Technology
- Modular Design with 43 inch or 48 inch Scrub Deck
- Safe hopper prop-rod engagement
- High capacity solution and recovery tanks
- 51 inch and 62 inch sweep path
- Dust Control with hopper raised
- 9.2 cu. ft, 60 inch variable high-dump hopper
- "One-Touch™" system activation.
- Midlite Grit™ 180 scrub brushes
- Proex/Wire main and polypropylene side brooms
- No tools maintenance access to primary systems

TYPICAL APPLICATIONS INCLUDE

- Warehouse/Distribution
- Manufacturing
- Parking Lots and Ramps
- Food and Beverage
- Transportation Facilities
- Stadiums and Arenas

The Captor™, designed with Total Clean™ Technology, is very comfortable and safe to use – by design. The Captor™ is also designed with features to make it easy to clean and maintain after cleaning. The result is a lower total cost of ownership and increased productivity that drives down the cost of cleaning.



Total Clean
by Nilfisk-Advance

Advance Captor™ 4300B & 4800B

Battery Rider Sweeper-Scrubbers



The ergonomic Clear-View™ design provides the operator with an unobstructed view of critical sweep zones without neck and back strain while keeping their head safely inside the machine.



The Tip-out recovery tank makes equipment clean-up safe and simple and helps keep your recovery tank fresh.



Battery roll-out functionality is standard on the Captor™ enabling you to run continuously. Complete battery exchange solutions available through Advance.

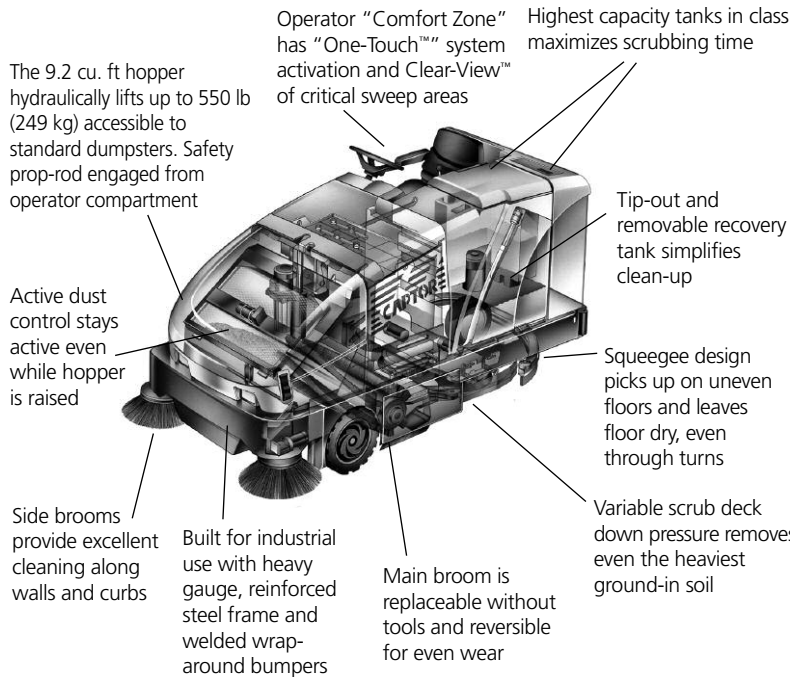

Industrial Strength Solutions...

- Our products are designed using innovative technology that increases productivity and drives down the cost to clean.
- You can get expert service and maintenance for your Advance machines from factory-trained personnel around the world. Fast parts delivery, too.
- Maintain peak performance with Nilfisk Genuine OEM Parts.

Nilfisk Genuine OEM Parts

Technical Specifications

Sweeping Path	51 in (130 cm) for 4300 model - (single side broom) 62 in (158 cm) for 4800 model - (dual side brooms) Squeegee scrub path is fully swept for all models
Main Broom	40 in (102 cm) length x 14 in (36 cm) diameter
Scrubbing Paths and Brushes	4300 - 43 in (110 cm); Scrub Brushes 3 x 15 in (38 cm) 4800 - 48 in (122 cm); Scrub Brushes 3 x 17 in (43 cm)
Sweeping Coverage Rates Per Hour	4300 with single side broom: 134,600 ft ² (12,500 m ²) 4800 with dual side brooms: 163,700 ft ² (15,210 m ²)
Scrubbing Coverage Rates Per Hour	4300 - 75,700 ft ² (7,030 m ²) 4800 - 84,500 ft ² (7,850 m ²)
Variable Scrub Pressure	Three scrub deck down pressure settings up to 400 lb (181 kg)
Transport Speed:	5.5 miles per hour (8.9 kph)
Motors	Propulsion 5 hp Scrubbing 1.5 hp (3) Sweeping 2 hp
Minimum Turn-around Aisle Width	118 in (300 cm) both left and right
Solution Tank Capacity	60 gal (227 L) for 4300 80 gal (303 L) for 4800
Recovery Tank Capacity	60 gal (227 L) for 4300 80 gal (303 L) for 4800
Recovery System	Dual vacuum capable of 70 inch waterlift
Battery Capacity	Available with battery up to 770 Ah. Unit comes standard with roll-out capability.
Ramp Climbing	12 deg. max (7.5 deg. while scrubbing)
Hopper	9.2 ft ³ (261 L) with 550 lb (250 kg) load capacity
High Dump	Variable to 60 in (152 cm)

Electric and Hydraulic System	Systems are electric powered with circuit overload protection with the exception of the hopper lift system which uses a hydraulic power unit.
Dust Control	78 ft ² (7.25 m ²) pleated panel filter captures dust. Timed electric filter shaker standard.
Squeegee	Four-sided, wrap-around design leaves floor dry, even on tight turns. Automatically lifts in reverse. Linotex is the standard material with other options available.
Machine Dimensions	105 in (267 cm) length x 50 in (127 cm) width x 59 in (150 cm) height (79 in with overhead guard) (width is for chassis without squeegee)
Weight	Machine only: 3,200 lb 770 Ah battery: 1,838 lb 80 gallon full solution tank: 667 lb Total Max weight: 5,702 lb
Part Numbers	Machine Only 4300B 56 303 417 4800B 56 303 418 Productivity Packages with 770 Ah Battery and Charger 4300B 56 303 411 4800B 56 303 414 Economy Packages with 510 Ah Battery and Charger 4300B 56 303 413 4800B 56 303 416

All models include MidLite Grit™ 180 scrub brushes, Proex/Wire main broom, and Polypropylene side broom(s)
Also available in propane, gas and diesel versions.

Specifications are subject to change without notice.



14600 21st Avenue North
Plymouth, MN 55447-3408
www.advance-us.com
Phone: 800-214-7700
Fax: 800-989-6566

396 Watline Avenue
Mississauga, Ontario, Canada L4Z 1X2
www.nilfisk-advance.com
Phone: 800-668-8400 or 905-712-3260
Fax: 800-263-5111 or 905-712-3255

©2006, Nilfisk-Advance, Inc.,
Printed in U.S.A., Form L1554A, 6-06